



**Design
Data**

Bridges

REV 12/19

Structural Bearing Assemblies
**Versiflex™ HLMR Disc Bearing
 Assemblies Uni-Directional
 DMG Series - 30%**

Design Basis: AASHTO 17th Edition w/ Interims – Section 14
Rotation: 0.02 Radians
Horizontal Capacity: 30% of Vertical Capacity
Movement: X = ±0.063”
 Y = Total movement capacity
Steel Strength: Fy = 50 ksi

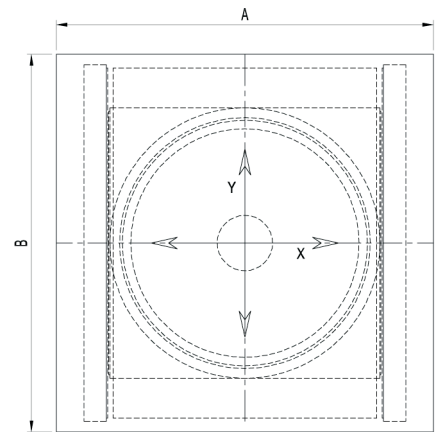
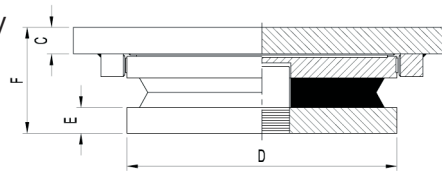

DMG SERIES - 30%

Model Number	Vertical Capacity (Klps)	Horizontal Capacity (Klps)	Movement						
			Y	A	B	C	D	E	F
DMG100	100	30	3	13.75	11.50	1.000	7.250	0.750	4.125
DMG200	200	60	3	17.25	14.00	1.000	9.500	0.750	4.875
DMG300	300	90	3	20.00	15.75	1.000	11.250	0.875	5.625
DMG400	400	120	3	22.25	17.50	1.000	12.750	1.000	6.125
DMG500	500	150	3	24.25	18.75	1.250	14.125	1.125	6.875
DMG600	600	180	3	26.25	20.25	1.250	15.250	1.250	7.375
DMG700	700	210	3	28.00	21.25	1.500	16.375	1.375	8.125
DMG800	800	240	3	29.50	22.50	1.500	17.375	1.500	8.500
DMG900	900	270	3	31.00	23.50	1.500	18.375	1.625	8.875
DMG1000	1000	300	3	32.50	24.50	1.750	19.250	1.625	9.375
DMG1250	1250	375	4	35.75	27.75	1.750	21.375	1.875	10.375
DMG1500	1500	450	4	38.75	29.75	2.000	23.250	2.000	11.375
DMG1750	1750	525	4	41.25	31.50	2.250	25.000	2.125	12.125
DMG2000	2000	600	4	44.00	33.25	2.250	26.750	2.250	12.875
DMG2250	2250	675	6	46.25	37.00	2.500	28.250	2.375	13.625
DMG2500	2500	750	6	48.75	38.50	2.500	29.875	2.500	14.250
DMG2750	2750	825	6	50.75	40.00	2.750	31.375	2.625	15.000
DMG3000	3000	900	6	52.75	41.50	2.750	32.625	2.750	15.500

Bridge the World with Leading Infrastructure Solutions

Versiflex™ HLMR Disc Bearing Assemblies Uni-Directional DMG Series - 30%

Structural Bearing Assemblies

2 of 2

DESIGN CONSIDERATIONS

- A. Bearing assembly component dimensions are based on assumed structural conditions and a skew of 0°.
- B. Translational movements (Y) shown in the chart reflect total required structural movement. Bearing components are detailed to accommodate the structural movement plus a ± 1 " factor of safety.
- C. Sole plates are designed for a welded connection to a steel girder flange. Sole plate dimensions will vary for bolted connections to steel flanges and/or for bearings supporting concrete superstructure elements.
- D. Masonry plate information has been excluded from the bearing details. Masonry plate dimensions are based on the allowable bearing stress of the substructure unit and the anchorage requirements.

A recommended method of determining the masonry plate thickness is to use a 60° load distribution through the plate. The effective loaded area should be used to calculate the bending moment of the plate and the concrete bearing pressure.

