

Owner's Manual

Pump-Pro®
Model 59-016-N



Manufactured by THE D. S. BROWN COMPANY, North Baltimore, Ohio 45872

Phone (419) 257-3561

November 17, 2008

www.dsbrown.com

Copyright – November 2008 by The DS Brown Company. All Rights Reserved



INTRODUCTION

Before installation is started, a few items of general nature should be considered. Please read the entire owner's manual before beginning installation.

The Pump-Pro is a self-contained lubricant-adhesive delivery system designed to supply up to 1.5 gallons of lubricant-adhesive per minute. The pump unit is driven by an electric motor powered by a gasoline generator. The motor can be turned on an off using the frame-mounted switch. Lubricant-adhesive is delivered to the joint trough a hand-held wand. Lubricant-adhesive flow can be turned on and off, as well as be metered by using conveniently located controlled valves.

START-UP

The following start-up procedure should be completed before every use:

1. Start the generator – Set the generator ignition switch to run and start by pulling the recoil starter.
Allow the generator to warm up before turning on the motor.
2. Verify the intake pump is submerged.
3. Turn on the motor.
4. Adjust lubricant-adhesive flow.

The Pump-Pro is now ready for normal operation

OPERATION

The Pump-Pro is very easy to operate by following these instructions:

1. The glue system operates using a positive displacement pump. The pump is fed by an intake pipe that is dropped into a lubricant-adhesive bucket. The glue pump feeds the operator control panel. Lubricant-adhesive flow is directed and metered by the 3-way valve (Figure 1). **DO NOT** meter flow using the on/off valve on the wand.
2. As shown in Figure 1, the glue can be:
 - a. Recirculated to the glue bucket (13A).
 - b. Fed through the applicator tip and recirculated to the glue bucket at the same time (13B).
 - c. Fed to the applicator tip only (13C).
3. Insert the applicator tip into the joint and open the wand valve. Apply lubricant-adhesive to the joint at a rate of 1 gallon every 150 feet.
4. Lubricant-adhesive should be applied to the sides of the joint near the surface.

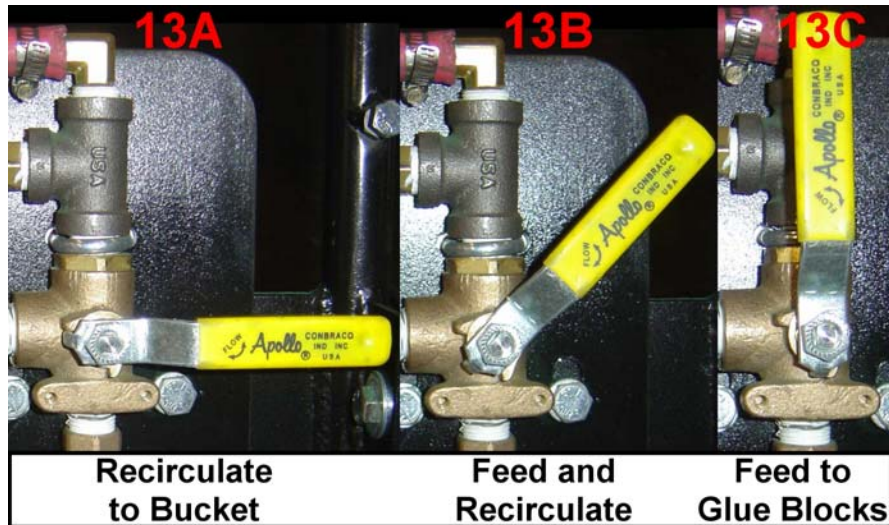

Figure 1 Glue System Operation

CLEAN UP

The Pump-Pro must be cleaned daily. Failure to do so **WILL** result in parts repair or replacement. Clean the Pump-Pro using the following method:

1. Turn off the pump and remove the suction and return lines from the glue bucket. Place the suction line in toluene or other solvent and feed the return line into a waste bucket. Open the glue return line. Run solvent through the system until all the glue has been flushed. Place the return line in the solvent bucket and continue to cycle solvent through the system for approximately 5 minutes.

WARNING

THE GLUE SYSTEM MUST BE FLUSHED AFTER EVERY USE. NOT DOING SO WILL RESULT IN PERMANENT DAMAGE TO ALL COMPONENTS IN THE GLUE SYSTEM.

2. With the suction and return lines still in the solvent, open the glue feed line and run solvent through the applicator tip. Remove all glue from the applicator tip using a putty knife.
3. Remove all glue from the inner surfaces of the compression blades. If necessary, soak the compression blades in solvent overnight and clean thoroughly in the morning.

TROUBLESHOOTING

A Pump-Pro glue delivery system that is properly maintained will give long and satisfactory performance.

NOTE: Before making any adjustment or loosening any fittings, make sure that:

- 1) any pressure in the lines has been vented through the suction or discharge lines.

- 2) the motor has been “locked out” so that it cannot inadvertently be started while work is being done on the pump. The best way to do this is unplug the motor from the generator.
- 3) the pump has been allowed to cool down to the point where there is no chance of anyone being burned.

Some of the following may help pinpoint the problem if trouble develops:

- A. Pump does not pump.
 1. Pump has lost its prime.
 - a. Air leak – Verify all fittings are secure on the suction side of the pump.
 - b. Low fluid level in bucket.
 2. Motor does not come up to speed.
 - a. Verify the pump drive sheave is secure on the shaft and the belt is engaging the sheave.
 3. Hose or fitting clogged.
 - a. Verify the hoses and fittings are free of glue build up and other foreign material.
 4. Piping is reversed.
 - a. Look for bubbles in the soapy water with the supply line in the bucket and the pump running. If air bubbles are coming out of the supply line the piping is reversed. Reverse the inlet and outlet hoses.
- B. Pump starts, then loses its prime.
 1. Supply tank is empty.
 2. Air leaks or air pockets in the suction line.
- C. Pump not up to capacity.
 1. Hose partially clogged.
 2. Air leak in the suction piping.
 3. Pump is running too slowly.
 4. Relief valve is set too low or is stuck open.

DO'S AND DON'TS

The following are a list of do's and don'ts for operation of your Pump-Pro to assure a safe, long, trouble-free operation.

1. Don't run the pump at speeds faster than 1,800 RPM.
2. Don't operate the pump without all guards being in place.
3. Don't operate the pump without the relief valve in the discharge piping.
4. Don't run the pump without any fluid for more than a minute. Operation under this condition may result in a heat build-up in the pump, which could destroy the pump.
5. Don't pump straight water through the system. Lubrication is necessary to maintain proper pump operation.
6. Do thoroughly clean the pump and piping system after each use with toluene.

STORAGE

If the Pump-Pro is to be stored or not used for three months or more, the pump must be drained and a light coat of non-detergent SAE 30 weight oil must be applied to all internal pump parts. Do this by feeding oil in the suction side and rotating the pump shaft by hand until oil is visible in the discharge port. Alternately, SAE 30 weight oil or its equivalent may be pumped through the entire system to avoid opening the piping at the pump ports. Drain excess oil from the system before storing.

CONTACTING D.S. BROWN

D.S. Brown Company
300 East Cherry St.
North Baltimore, OH 45872

Call D.S. Brown toll free at (800) 848-1730 and ask for Pump-Pro Technical Assistance.

PARTS LIST

When ordering parts, please have the model and serial number available.

Description: Pump-Pro

Model: 59-016-N

Serial Number: _____

BOM Table		
ORACLE NUMBER	DESCRIPTION	QTY.
59-016-01	CART	1
59-016-02	HANDLE	1
59-016-03	GLUE WAND ASSEMBLY	1
59-016-04	GLUE CONTROL PANEL	1
59-016-05	GENERATOR	1
59-016-06	PUMP ASSEMBLY	1
59-016-07-01	ELECTRICAL BOX	1
59-016-08	SWITCH MOUNT PLATE	1
59-372	SWIVEL CASTER	4
59-602	INTAKE PIPE	1
59-604	HOSE BARB	3
59-582	#12 Hose Clamp	3
59-603	FEED ELBOW	1
59-606	HOSE	1
X	HARDWARE	20
X	HARDWARE	20
X	HARDWARE	5
X	HARDWARE	1
X	HARDWARE	2
X	HARDWARE	5
X	HARDWARE	1

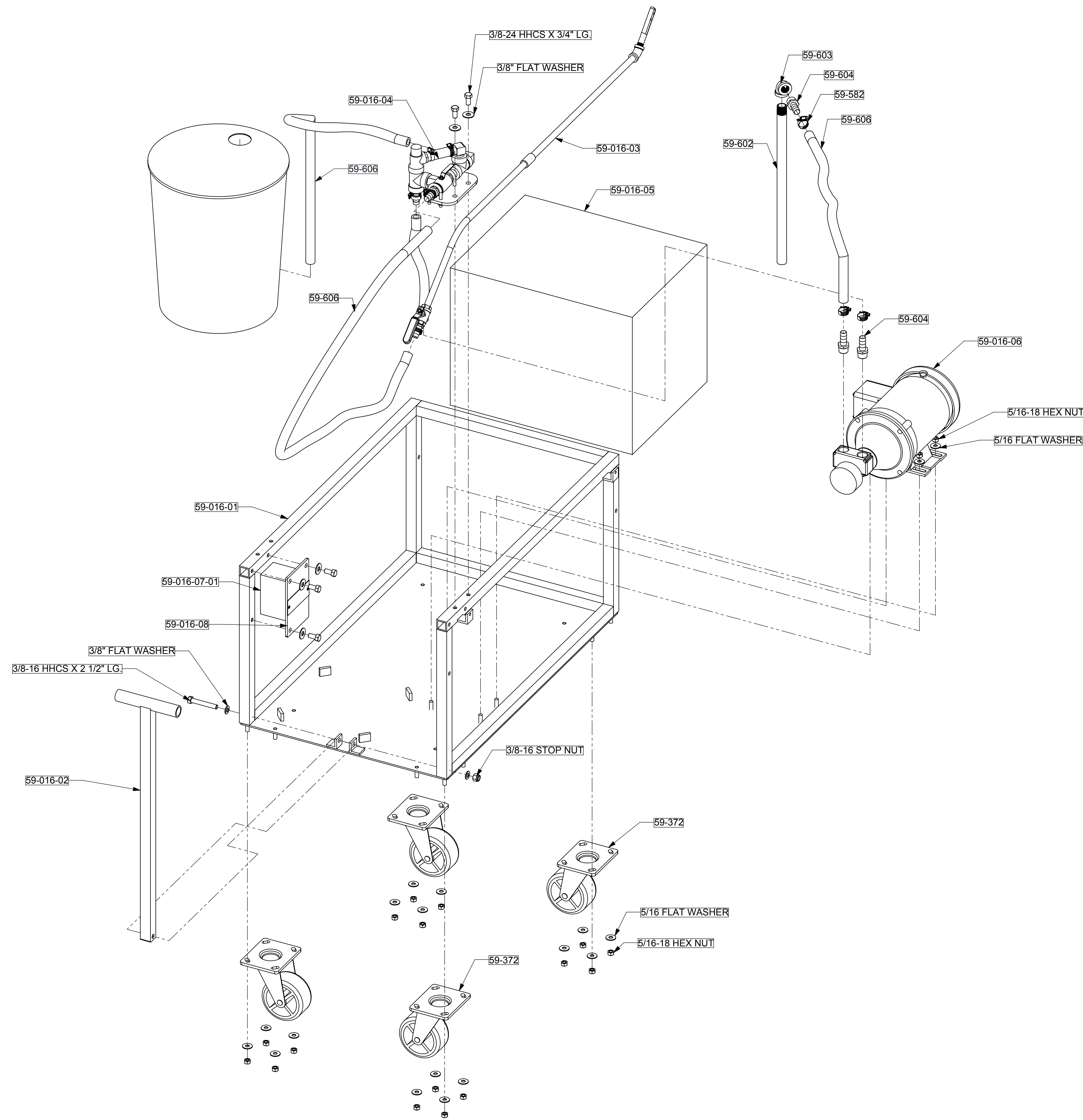

UNLESS OTHERWISE SPECIFIED:
 DIMENSIONS ARE IN INCHES
 TOLERANCES:
 FRACTIONAL: ±1/16"
 ANGULAR: MACH ±0.5° BEND ±1°
 TWO PLACE DECIMAL: ±0.005"
 THREE PLACE DECIMAL: ±0.001"
 THE INFORMATION CONTAINED IN THIS DRAWING IS THE SOLE PROPERTY OF D.S. BROWN. ANY REPRODUCTION IN PART OR AS A WHOLE WITHOUT THE WRITTEN PERMISSION OF D.S. BROWN IS PROHIBITED.

D.S. BROWN
 300 East Cherry St. North Baltimore, Ohio 45872

PUMP-PRO PARTS LIST

DRAWN BY: JSM	SCALE: NTS	SHEET: 5 OF 5
REV: X	DATE: 09-15-08	DRAWING NO:
JOB: 1024139	SIZE: D	DE-08-208-04

DE-08-208-04