

Versiflex™ HLMR Bearing Uni-Directional PMCG Series

Design Basis: AASHTO 17th Edition w/ Interims – Section 14
 Rotation: 0.03 Radians
 Horizontal Capacity: 30% of Vertical Capacity
 Movement: X = ±0.063"
 Y = As shown below
 Steel Strength: Fy = 50 ksi

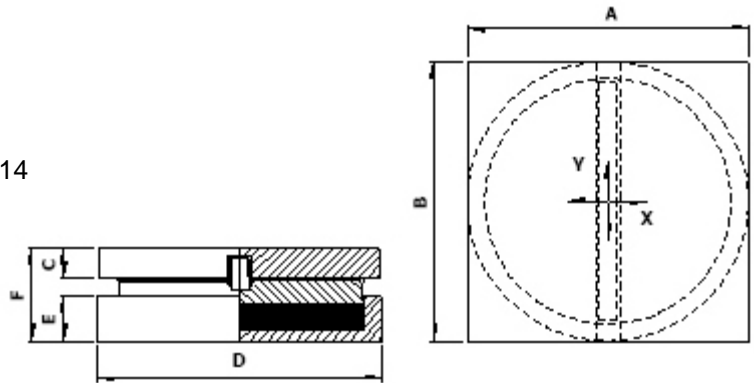

PMCG Series - 30%									
Model Number	Vertical Capacity (kips)	Horizontal Capacity (kips)	Movmnt.	Dimensions (in)					
			Y	A	B	C	D	E	F
PMCG100	100	30	3	9.000	12.250	2.5	9.000	2.250	5.875
PMCG150	150	45	3	10.750	13.500	2.75	10.750	2.500	6.25
PMCG200	200	60	3	12.250	14.750	2.75	12.250	3.000	6.875
PMCG250	250	75	3	13.750	16.000	3	13.750	3.250	7.25
PMCG300	300	90	3	15.000	17.000	3.25	15.000	3.500	7.875
PMCG350	350	105	3	16.000	17.750	3.25	16.000	3.750	8.25
PMCG400	400	120	3	17.250	18.750	3.5	17.250	4.000	8.75
PMCG450	450	135	3	18.250	19.500	3.5	18.250	4.250	9.125
PMCG500	500	150	3	19.250	20.250	3.75	19.250	4.500	9.75
PMCG550	550	165	3	20.000	21.000	3.75	20.000	4.500	9.75
PMCG600	600	180	3	20.750	21.500	4	20.750	4.750	10.25
PMCG650	650	195	3	21.750	22.250	4	21.750	5.000	10.625
PMCG700	700	210	3	22.500	23.000	4	22.500	5.250	10.875
PMCG750	750	225	3	23.250	23.500	4.25	23.250	5.250	11.125
PMCG800	800	240	3	24.000	24.000	4.25	24.000	5.500	11.375
PMCG850	850	255	3	24.750	24.750	4.25	24.750	5.750	11.625
PMCG900	900	270	3	25.500	25.500	4.5	25.500	6.000	12.25
PMCG950	950	285	3	26.000	26.000	4.5	26.000	6.000	12.25
PMCG1000	1000	300	3	27.000	27.000	4.5	27.000	6.250	12.5
PMCG1100	1100	330	4	28.000	28.250	4.75	28.000	6.500	13.125
PMCG1200	1200	360	4	29.250	29.250	5	29.250	6.750	13.625
PMCG1300	1300	390	4	30.500	30.500	5	30.500	7.000	14
PMCG1400	1400	420	4	31.750	31.750	5.25	31.750	7.250	14.5
PMCG1500	1500	450	4	32.750	32.750	5.25	32.750	7.500	14.875
PMCG1600	1600	480	4	33.750	33.750	5.5	33.750	7.750	15.375
PMCG1700	1700	510	4	34.750	34.750	5.5	34.750	8.000	15.75
PMCG1800	1800	540	4	35.750	35.750	5.75	35.750	8.000	15.875
PMCG1900	1900	570	4	36.500	36.500	5.75	36.500	8.250	16.25
PMCG2000	2000	600	4	37.750	37.750	6	37.750	8.500	16.875
PMCG2250	2250	675	6	40.000	40.000	6.25	40.000	9.000	17.75
PMCG2500	2500	750	6	41.750	41.750	6.5	41.750	9.500	18.5
PMCG2750	2750	825	6	44.000	44.000	6.75	44.000	10.000	19.375
PMCG3000	3000	900	6	46.000	46.000	7	46.000	10.500	20.25
PMCG3500	3500	1050	6	49.500	49.500	7.5	49.500	11.250	21.75
PMCG4000	4000	1200	6	52.750	52.750	7.75	52.750	12.000	22.875
PMCG5000	5000	1500	6	59.000	59.000	8.75	59.000	13.250	25.5

Versiflex™ HLMR Bearing Design Considerations:

- Bearing assembly component dimensions are based on assumed structural conditions and a skew of 0°.
- Translational movements (Y) shown in the chart reflect total required structural movement. Bearing components are detailed to accommodate the structural movement plus a ± 1 " factor of safety.
- Sole plates are designed for a welded connection to a steel girder flange. Sole plate dimensions will vary for bolted connections to steel flanges and/or for bearings supporting concrete superstructure elements.
- Masonry plate information has been excluded from the bearing details. Masonry plate dimensions are based on: 1) allowable bearing stress of substructure unit and 2) anchorage requirements.

A recommended method of determining the masonry plate thickness is to use a 60° load distribution through the plate. The effective loaded area should be used to calculate the bending moment of the plate and the concrete bearing pressure.

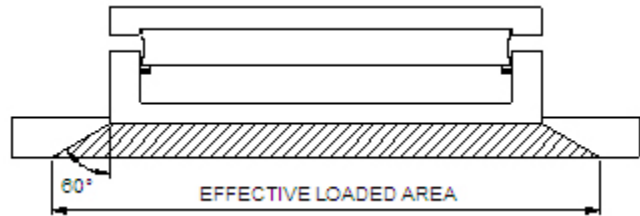

- Sole plate dimensions are typically based on the use of PTFE on guided surfaces. However, low co-efficient of friction materials are utilized when horizontal forces require selection of un-economical plate thicknesses.