

Versiflex™ HLMR Bearing Uni-Directional PMCG Series

Design Basis: AASHTO 17th Edition w/ Interims – Section 14

Rotation: 0.03 Radians

Horizontal Capacity: 10% of Vertical Capacity

Movement: X = ±0.063"

Y = As shown below

Steel Strength: Fy = 50 ksi

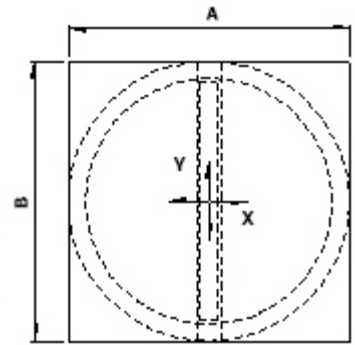
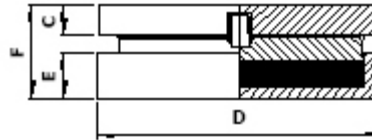

PMCG Series - 10%									
Model Number	Vertical Capacity (kips)	Horizontal Capacity (kips)	Movmnt.	Dimensions (in)					
			Y	A	B	C	D	E	F
PMCG100	100	10	3	8.50	12.00	1.75	8.50	2.00	5.000
PMCG150	150	15	3	10.00	13.50	1.75	10.00	2.25	5.125
PMCG200	200	20	3	11.00	14.50	2.00	11.00	2.25	5.375
PMCG250	250	25	3	12.25	15.50	2.00	12.25	2.50	5.625
PMCG300	300	30	3	13.25	16.50	2.00	13.25	2.75	5.875
PMCG350	350	35	3	14.25	17.25	2.00	14.25	2.75	5.875
PMCG400	400	40	3	15.00	18.00	2.00	15.00	3.00	6.125
PMCG450	450	45	3	16.00	18.75	2.25	16.00	3.00	6.375
PMCG500	500	50	3	16.75	19.50	2.25	16.75	3.25	6.625
PMCG550	550	55	3	17.75	20.25	2.25	17.75	3.50	6.875
PMCG600	600	60	3	18.25	20.75	2.25	18.25	3.50	6.875
PMCG650	650	65	3	19.00	21.50	2.25	19.00	3.75	7.250
PMCG700	700	70	3	19.75	22.00	2.25	19.75	3.75	7.250
PMCG750	750	75	3	20.25	22.50	2.25	20.25	3.75	7.250
PMCG800	800	80	3	21.25	23.25	2.50	21.25	4.00	7.750
PMCG850	850	85	3	21.75	23.75	2.50	21.75	4.00	7.750
PMCG900	900	90	3	22.25	24.25	2.50	22.25	4.25	8.000
PMCG950	950	95	3	23.00	24.75	2.50	23.00	4.25	8.000
PMCG1000	1000	100	3	23.50	25.25	2.50	23.50	4.50	8.250
PMCG1100	1100	110	4	24.50	27.25	2.50	24.50	4.50	8.375
PMCG1200	1200	120	4	25.50	28.00	2.75	25.50	4.75	8.875
PMCG1300	1300	130	4	26.75	29.00	2.75	26.75	5.00	9.125
PMCG1400	1400	140	4	27.50	29.75	2.75	27.50	5.00	9.125
PMCG1500	1500	150	4	28.75	30.75	2.75	28.75	5.25	9.375
PMCG1600	1600	160	4	29.50	31.50	2.75	29.50	5.50	9.750
PMCG1700	1700	170	4	30.50	32.25	2.75	30.50	5.50	9.750
PMCG1800	1800	180	4	31.25	33.00	3.00	31.25	5.75	10.250
PMCG1900	1900	190	4	32.25	33.75	3.00	32.25	6.00	10.500
PMCG2000	2000	200	4	32.75	34.25	3.00	32.75	6.00	10.500
PMCG2250	2250	225	6	34.75	38.00	3.00	34.75	6.50	11.125
PMCG2500	2500	250	6	36.75	39.75	3.25	36.75	6.75	11.625
PMCG2750	2750	275	6	38.50	41.25	3.25	38.50	7.00	11.875
PMCG3000	3000	300	6	40.00	42.50	3.25	40.00	7.50	12.500
PMCG3500	3500	350	6	43.25	45.25	3.50	43.25	8.00	13.250
PMCG4000	4000	400	6	46.00	47.75	3.75	46.00	8.50	14.125
PMCG5000	5000	500	6	51.50	52.50	4.00	51.50	9.50	15.500

Versiflex™ HLMR Bearing Design Considerations:

- Bearing assembly component dimensions are based on assumed structural conditions and a skew of 0°.
- Translational movements (Y) shown in the chart reflect total required structural movement. Bearing components are detailed to accommodate the structural movement plus a ± 1 " factor of safety.
- Sole plates are designed for a welded connection to a steel girder flange. Sole plate dimensions will vary for bolted connections to steel flanges and/or for bearings supporting concrete superstructure elements.
- Masonry plate information has been excluded from the bearing details. Masonry plate dimensions are based on: 1) allowable bearing stress of substructure unit and 2) anchorage requirements.

A recommended method of determining the masonry plate thickness is to use a 60° load distribution through the plate. The effective loaded area should be used to calculate the bending moment of the plate and the concrete bearing pressure.

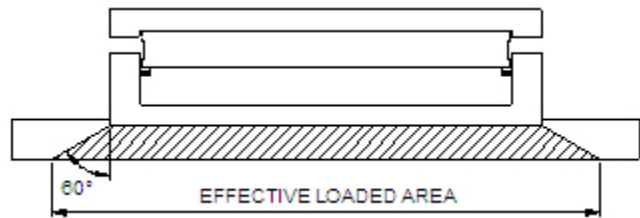

- Sole plate dimensions are typically based on the use of PTFE on guided surfaces. However, low co-efficient of friction materials are utilized when horizontal forces require selection of un-economical plate thicknesses.