



Revised 05/11

Structural Bearing Assemblies | Disc Bearing Assembly

At the time of initial publication of the AASHTO LRFD code, disc bearings were a patented product produced by one manufacturer. Ten years later, disc bearings are increasingly specified as HLMR bearing alternatives, yet little design guidance is provided in the current code. Therefore, designers should be attentive to some particular details when specifying disc bearings.

Lack of Information to Design Disc Thickness

As is the case with all elastomers, compression deflection of polyether urethane components is dependent upon their shape factor. Also, there is no mathematical relationship between the shape factor and compressive modulus. AASHTO requires that the instantaneous deflection not exceed 10% of the unstressed disc thickness or an additional 8% of the unstressed disc thickness due to creep. However, the code provides no shape and hardness dependent stress-strain relationships from which to make a determination; therefore, an empirical relationship must be established by testing.

Allowable Compressive Stress on Urethane Disc

AASHTO Section 14.7.8.3 limits the average compressive stress on the disc to 5000 psi and requires the disc OD to be based on the smallest plan area of the disc when the outer surface is not vertical. Although not specifically stated in AASHTO, the hole in the disc to accommodate the shear resisting pin should also be deducted from compressive area calculations.

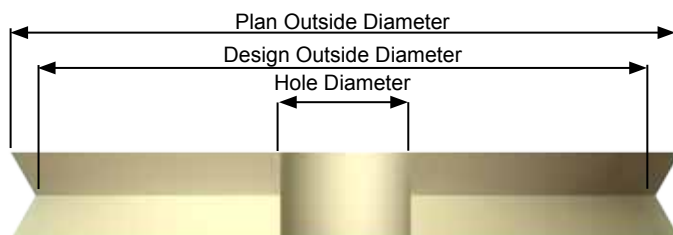

Confinement of Elastomer Against Lateral Expansion

Polyether urethane compounds formulated to accommodate design rotations without liftoff will bulge under vertical loads. Therefore, limiting rings of a depth at least 0.03

times the disc diameter should be required to prevent excessive slip and resulting vertical deflections. Intentionally roughened surfaces on the top and bottom plate in contact with the disc have also been used to confine the elastomer.

Location of Axis of Rotation

For the purpose of establishing the forces and deformations imposed on disc bearings, AASHTO Section 14.7.8.1 defines the axis of rotation at the mid-height of the disc. Once placed under a stringer/girder, the axis of rotation of the system is moved upward to the neutral axis of the composite superstructure system. Therefore, rotations and resulting translations of individual components (upper bearing plate and pin) must be considered in design. Detailing options include placing fixity of the shear resisting pin in either the upper or lower plate as shown below.

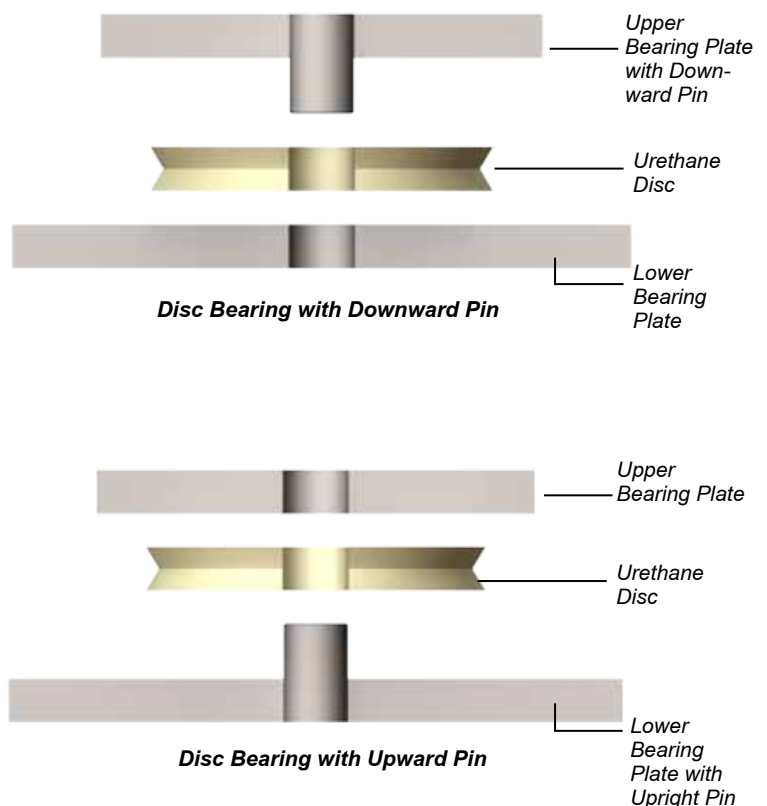

Design Rotation & Horizontal Design Clearance

AASHTO Section 14.4.2.2.2 states that disc bearings are less likely to experience hard contact between metal components, and therefore, do not require an additional 0.005 radian allowance for rotation due to fabrication and installation tolerances. However, engagement of the shear resisting pin into the upper or lower plate is a potential source for metal-to-metal contact as the bearing is rotated and loaded vertically. The following picture shows metal-to-metal contact after proof load testing. Therefore, designers must ensure that contact will not occur during service rotations.



Damage from metal-to-metal contact in lower plate

Design of Shear Resisting Mechanism

AASHTO provides no guidance on the design of pin style shear resisting mechanisms. However, analysis and testing indicate that shear strength, not bending, is the criteria that should be used to determine pin diameter. Pilot tests have demonstrated that several details are important in determining the horizontal load capacity. They include - 1) thickness of the upper or lower plate that the pin is anchored into (thicker is better); 2) yield strength of pin and plate material (high strength pins fixed in lower strength plates will fail by local deformation of plate); 3) connection detail between pin and plate (threaded was best); and 4) contribution of urethane disc (significant - although ignored in design). Without guidance on how much, if any, contribution should be allowed from the urethane disc, it is recommended that a horizontal proof test be performed without the urethane disc. Therefore, design equations for horizontal capacity, at a minimum, should include pin diameter and embedded plate thickness.

Uplift Details

Repetitive uplift on bearings due to service load conditions should be avoided by strategic placement of dead load. However, uplift restraint bearings can be designed for low probability extreme events like earthquakes. In an uplift situation, the horizontal load capacity of the bearing system will be reduced because the contribution from the urethane disc will be eliminated. This situation should be accounted for during design and proof testing without the urethane disc.

Replaceability

Section 14.8 of the AASHTO LRFD design specification implies that all bearings shall be detailed to allow replacement by jacking the structure less than 0.375 inches. The fabrication of a 4-plate system (masonry, lower bearing, upper bearing, and sole plate) as detailed below allows for easy removal with a small amount of jacking. Due to engagement of the shear pin into the masonry plate, the 3-plate design will require considerably more jacking than suggested in the AASHTO code and therefore is not recommended.

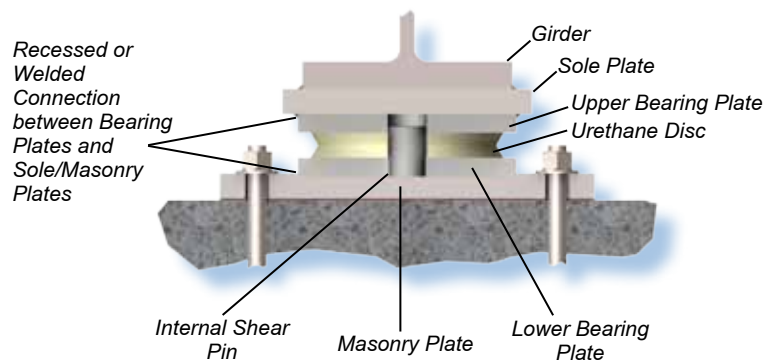

4-Plate Design

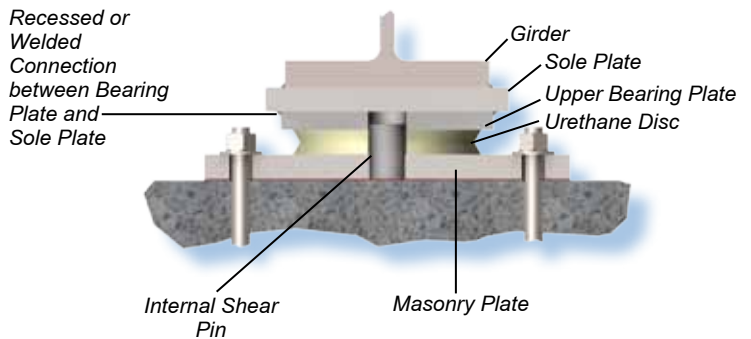

3-Plate Design